

## e-Series Selector Battery Switch with AFD\*

PN 9002e

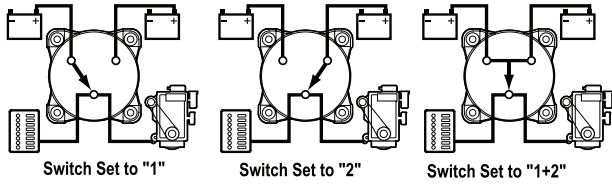

Switch Set to "1"

Switch Set to "2"

Switch Set to "1+2"

### Features

- Selects battery bank 1 or battery bank 2, or 1+2 for charging or emergency starting
- For switching battery banks in applications requiring high power output, reliability, and low heat generation
- Alternator Field Disconnect (AFD) protects the diodes in the alternator in the event of the switch being switched to the OFF position while the engine is running

#### Tin-plated copper studs:

- 3/8"-16 (M10) provide maximum conductivity and corrosion resistance
- One-piece to reduce risk of overheating
- 7/8" (22.22mm) length to accept multiple cable terminals

#### Case design:

- Allows surface mounting or rear panel mounting
- Accepts up to 4/0 AWG (120 mm<sup>2</sup>) battery cables

### Specifications

Cranking Rating: 10 sec.	2,000 Amperes DC
Cranking Rating: 1 min.	1,000 Amperes DC
Intermittent Rating: 5 min. (UL 1107)	600 Amperes DC
Continuous Rating: (UL 1107)	350 Amperes DC
Terminal Stud, Tin-Plated Copper	3/8"-16 (M10)
Torque	140 in-lb (15.82 N-m)
Cable Size to Meet Ratings**	4/0 AWG (120 mm <sup>2</sup> )
Maximum Voltage Rating	32 Volts DC
Ignition Protected	
CE marked	

### Agency Specifications

- Meets all American Boat and Yacht Council (ABYC) requirements for battery switches
- UL Listed - UL 1107 for electric power switches
- Meets UL 1500 and SAE J1171 external ignition protection requirements

### Guarantee

Any Blue Sea Systems product with which a customer is not satisfied may be returned for a refund or replacement at any time.

For information about Blue Sea Systems Engine Starting Standard, go to [www.blueseasea.com](http://www.blueseasea.com).

\* Alternator Field Disconnect

\*\* Reducing cable sizes will reduce current ratings

**Blue Sea Systems Inc.**  
425 Sequoia Drive  
Bellingham, WA 98226 USA

**Phone (360) 738-8230**  
**Fax (360) 734-4195**  
E-mail [conductor@blueseasea.com](mailto:conductor@blueseasea.com)  
[www.blueseasea.com](http://www.blueseasea.com)

## Caution

- Disconnect positive battery terminal before installing.
- Débranchez la cosse positive de la batterie avant de l'installer.
- Desconecte el terminal positivo de la batería antes de la instalación.
- Prima di eseguire l'installazione, disconnettere il terminale positivo della batteria.
- Consult marine electrical professional for proper wiring application.
- Consultez un professionnel de l'électricité marine pour installer le câblage correctement.
- Consulte a un electricista marino profesional para la aplicación de alambrado apropiada.
- Per assicurarsi che i cavi siano correttamente collegati, rivolgersi ad un elettricista specializzato in motori marini.

## Installation

- Mount in an easily accessible location close to the batteries.
- Montez-le dans un endroit facilement accessible près des batteries.
- Monte en una ubicación fácilmente accesible cerca de la batería.
- Montare in un punto facilmente accessibile e vicino alle batterie.
- Attach one 4/0 AWG cable per terminal to meet ratings.
- Raccordez un câble 95mm<sup>2</sup> par cosse pour respecter les spécifications.
- Sujete un cable 95mm<sup>2</sup> por terminal de acuerdo a la clasificación.
- Attaccare un cavo 95mm<sup>2</sup> per conformarsi alle tarature.
- Refer to the latest edition of NFPA 302 and/or ABYC E11 Standard for installation information.
- Battery cable terminals must be attached under nut and lock washer. Torque 140 in-lb (15.82 N-m).
- Les cosses des câbles de batterie doivent être fixées sous la rondelle de sûreté et l'écrou – couple de serrage de 15,82 N-m (140 lb-po).
- Los terminales de los cables de batería deberán ser sujetados debajo de la tuerca y la arandela. Apriéte los a una torsión de 15,82 N-m (140 lbs-pul).
- I terminali del cavo della batteria vanno attaccati con un dado e una rondella elastica: coppia di 15,82 N-m (140 lbs-in).
- AFD: Cut the field wire from the alternator to the voltage regulator; connect one end to F1, and the other end to F2.
- AFD: Coupez le fil allant de l'alternateur au régulateur de tension ; connectez-en une extrémité à F1 et l'autre à F2.
- AFD: Corte el cable de campo del alternador al regulador de voltaje, conecte un extremo al punto F1 y el otro extremo al punto F2.
- AFD: Staccare il cavo che unisce l'alternatore al regolatore di tensione; connettere un polo a F1 e l'altro a F2.

## Operation

- Turn all appliances off before turning the battery switch to OFF.
- Éteignez tous les appareils électriques avant de mettre l'interrupteur de batterie sur ARRÊT.
- Apague todos los artefactos antes de girar el interruptor de batería a APAGADO (OFF).
- Spegnere tutte le apparecchiature prima di muovere l'interruttore della batteria su OFF (spento).
- Do not switch to OFF while engine is running.
- Ne le mettez pas sur ARRÊT alors que le moteur tourne.
- No coloque el interruptor en APAGADO (OFF) mientras que el motor esté funcionando.
- Non muovere l'interruttore su OFF (spento) quando il motore è in moto.

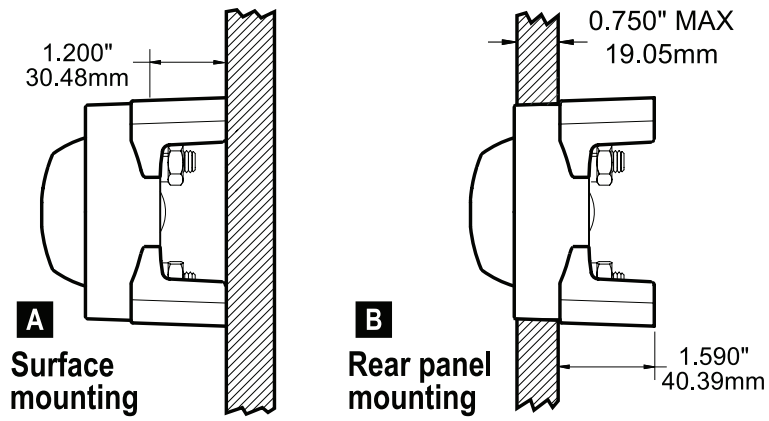

**Switch Mounting Options**

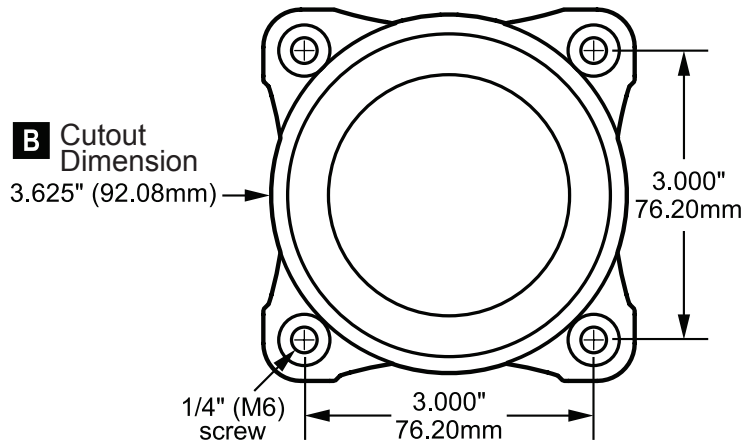

**e-Series Battery Switch Dimensions**

